

REINHOLD ENVIRONMENTAL Ltd.



2011 APC Round Table & Expo Presentation

July 11-12, 2011, in Cleveland, OH / Hosted by FirstEnergy

All presentations posted on this website are copyrighted by Reinhold Environmental, Ltd (RE). Any unauthorized downloading, attempts to modify or to incorporate into other presentations, link to other websites, or obtain copies for any other uses than the training of attendees to RE's Conferences is expressly prohibited, unless approved in writing by RE or the original presenter. RE does not assume any liability for the accuracy or contents of any materials contained in this library which were presented and/or created by persons who were not employees of RE.

Utility MACT PM Control with WESP Technology

SIEMENS

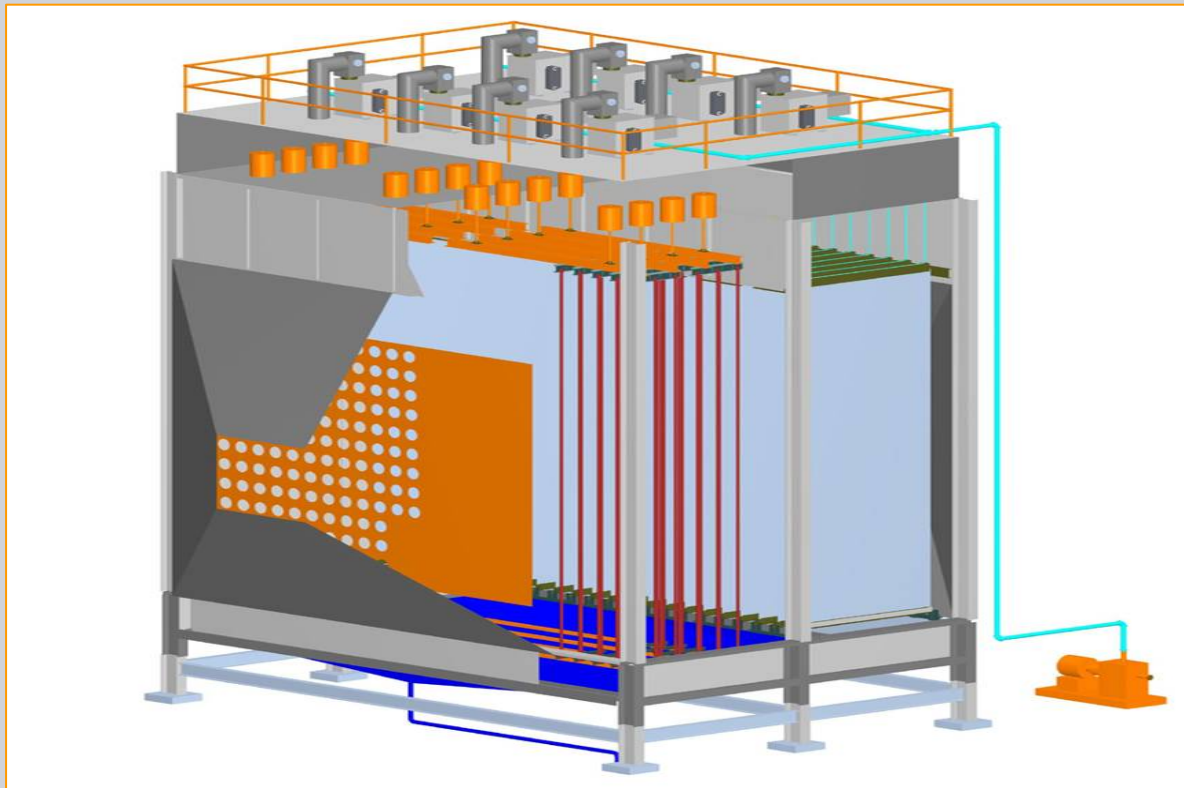

Buzz Reynolds VP Wet ESP
Siemens Environmental Systems & Services

U- MACT PM Control with WESP Technology

1. Proposed Standards for New & Existing Units
2. Strategic Considerations
3. What Total PM means
4. Impact of Particle Size Distribution
5. Existing Plant Control Equipment vs Proposed Standards
6. Possible WESP Application
7. Why WESP
8. Where it is installed
9. How has it performed
11. New WESP Applications
 - Plasma ESP
 - Hybrid Dry-Wet ESP
12. Acknowledgments

Proposed Standards

Regulated Pollutant	Primary Fuel	Proposed Emission Limits for New Units	Proposed Emission Limits for Existing Units
Acid Gases	Bituminous Sub-bituminous Lignite	HCL=0.30 lb/GWh (~0.03 ppmvd @ 3%O ₂) or SO ₂ = 0.40 lb/MWh (~0.042 lb/MMBtu)	HCL=0.0020 lb/MMBtu (~2ppmvd @ 3%O ₂) or SO ₂ = 0.20 lb/MMBtu
Non-Hg HAP Metals	Bituminous Sub-bituminous Lignite	Total PM= 0.05 lb/MWh (~0.0052 lb/MMBtu) or Total Non-Hg HAP Metals = 0.000042 lb/MWh (~4.2 lbs/TBtu) or Individual HAP Metal Limits	Total PM = 0.030 lb/MMBtu or Total Non-Hg Metals = 0.000040 lb/MMBtu or Individual Non-Hg HAP Metals
Mercury	Bituminous Sub-bituminous	0.000010 lb/GWh (~0.001 lb/TBtu)	1.2 lb/TBtu* (revised)
	Lignite	0.040 lb/GWh (~4.2 lb/TBtu)	4.0 lb/TBtu

Individual Metal Limits

Summary of UPLs using emission averages -- Coal-fired units/PM emissions

Pollutant	Existing					New			
	Mean (lb/MMBtu)	UPL (lb/MMBtu)	Number of units in the floor	lb/TBtu	Floor value	Mean (lb/MMBtu)	UPL (lb/MMBtu)	Number of units in the floor	
PM total	0.0116	0.0264	131		0.03	lb/MMBtu	0.002821	0.01307	1
Metal total	0.0000142	0.0000376	131		0.00004	lb/MMBtu	0.0000015	0.0000021	1
Antimony (Sb)	2.0981E-07	5.4934E-07	131	0.549338329	0.6	lb/TBtu	3.1217E-09	1.6294E-08	1
Arsenic (As)	4.1029E-07	1.0816E-06	131	1.081629882	2.0	lb/TBtu	9.4342E-09	1.4847E-08	1
Beryllium (Be)	4.8952E-08	1.3337E-07	131	0.133372821	0.2	lb/TBtu	1.6477E-09	4.7302E-09	1
Cadmium (Cd)	9.8523E-08	2.1212E-07	131	0.212120593	0.3	lb/TBtu	8.1778E-09	4.0907E-08	1
Chromium (Cr)	1.2160E-06	2.8137E-06	131	2.813717862	3	lb/TBtu	1.3625E-07	6.5805E-07	1
Cobalt	2.8224E-07	7.1184E-07	131	0.711841034	0.8	lb/TBtu	1.4315E-08	7.4379E-08	1
Lead (Pb)	3.3617E-07	1.2792E-06	131	1.279165372	2	lb/TBtu	2.5577E-08	8.0333E-08	1
Manganese (Mn)	1.6846E-06	4.1963E-06	131	4.196344044	5	lb/TBtu	1.2154E-07	1.8479E-07	1
Nickel (Ni)	1.4138E-06	3.3913E-06	131	3.391265314	4	lb/TBtu	1.1961E-07	3.5102E-07	1
Selenium (Se)	1.6204E-06	5.5311E-06	131	5.531080708	6	lb/TBtu	1.3678E-08	3.1240E-08	1

Strategic Considerations

▪ **Utilize existing assets**

- Look to leverage existing APC equipment (dry ESP)
- Think of Boiler & APC equipment as an integrated system
- How to optimize the system, not just a component

▪ **Think long term**

- Limits will get more stringent as EPA collects more data
- Design / build for worst case condition to avoid future add-ons
- Look to limits for new coal plants – 0.005 lb/MMBtu or 1.5 ppm

▪ **Minimize risk**

- Build in enough safety margin
- Understand appropriate test method
- Allow for Operational flexibility
- Belts & Suspenders – complementary APC equipment

What Total PM Means

Filterable Particulate

- Exists as solid or liquid particulate
- Collected in “front-half” filter of PM test apparatus

Condensable Particulate

- Vapors that condense at ambient temperatures
 - **$\text{SO}_3 - \text{H}_2\text{SO}_4$ sulfuric acid mist**
 - **Toxic metals – cadmium, chromium, lead, magnesium**
- Collected in “back-half” impingers in PM test apparatus
- Has not been required to date to meet PM standards
- EPA estimates that 78% of PM 2.5 emissions are condensable

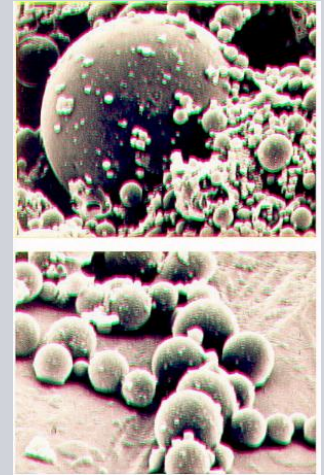

Fly Ash Particles

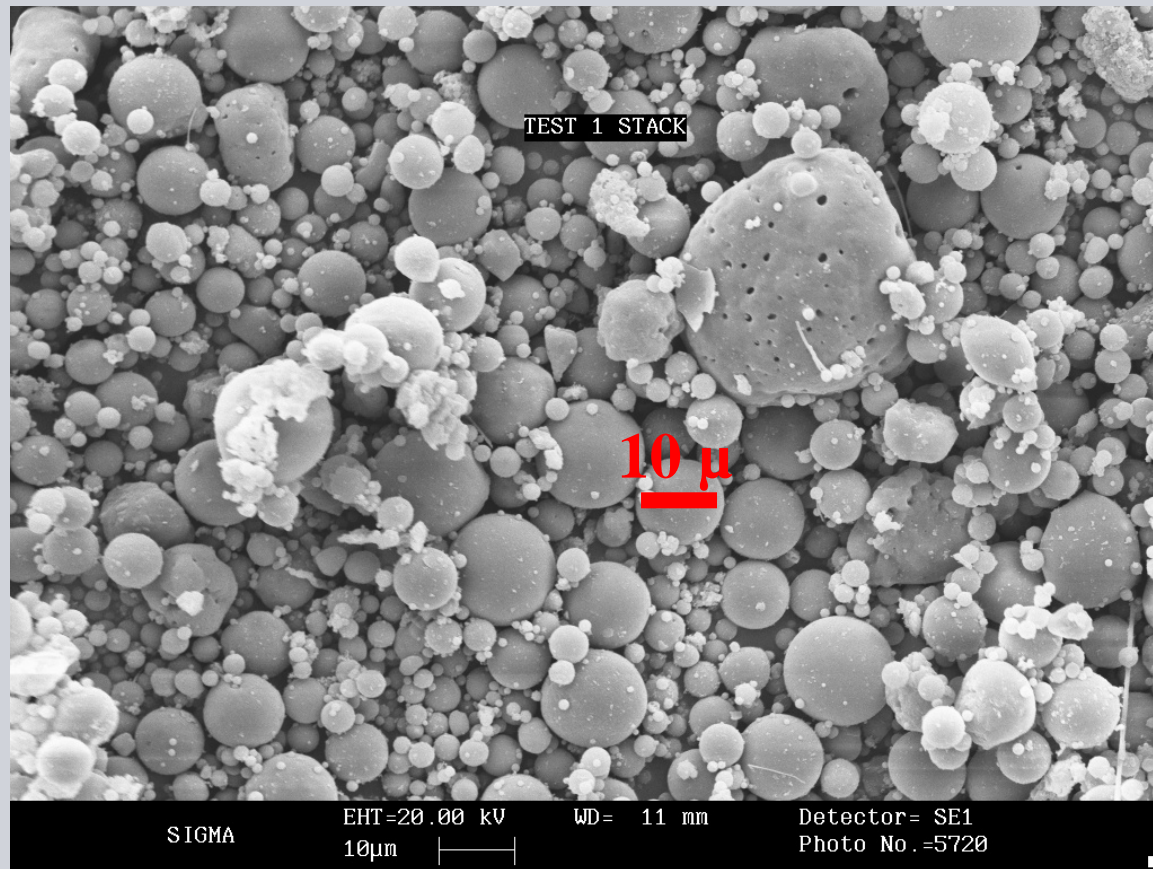

of Particles in 1 Cubic Inch (1 micron = 0.000039")

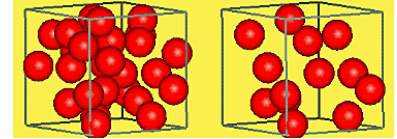

Particle Size	Number of Particles =1/(4/3πr ³)	Compared to 10 microns	Surface Area of Particles = P# * 4πr ²	Compared to 10 microns
0.5	128,850,993,811,609	8000x	153,846	20x
1	16,106,374,226,451	1000x	76,923	10x
2.5	1,030,807,950,493	64x	30,769	4x
5	128,850,993,812	8x	15,385	2x
10	16,106,374,226		7,692	

Particle Size Distribution from a WFGD by Mass



Courtesy of Clean Air Engineering

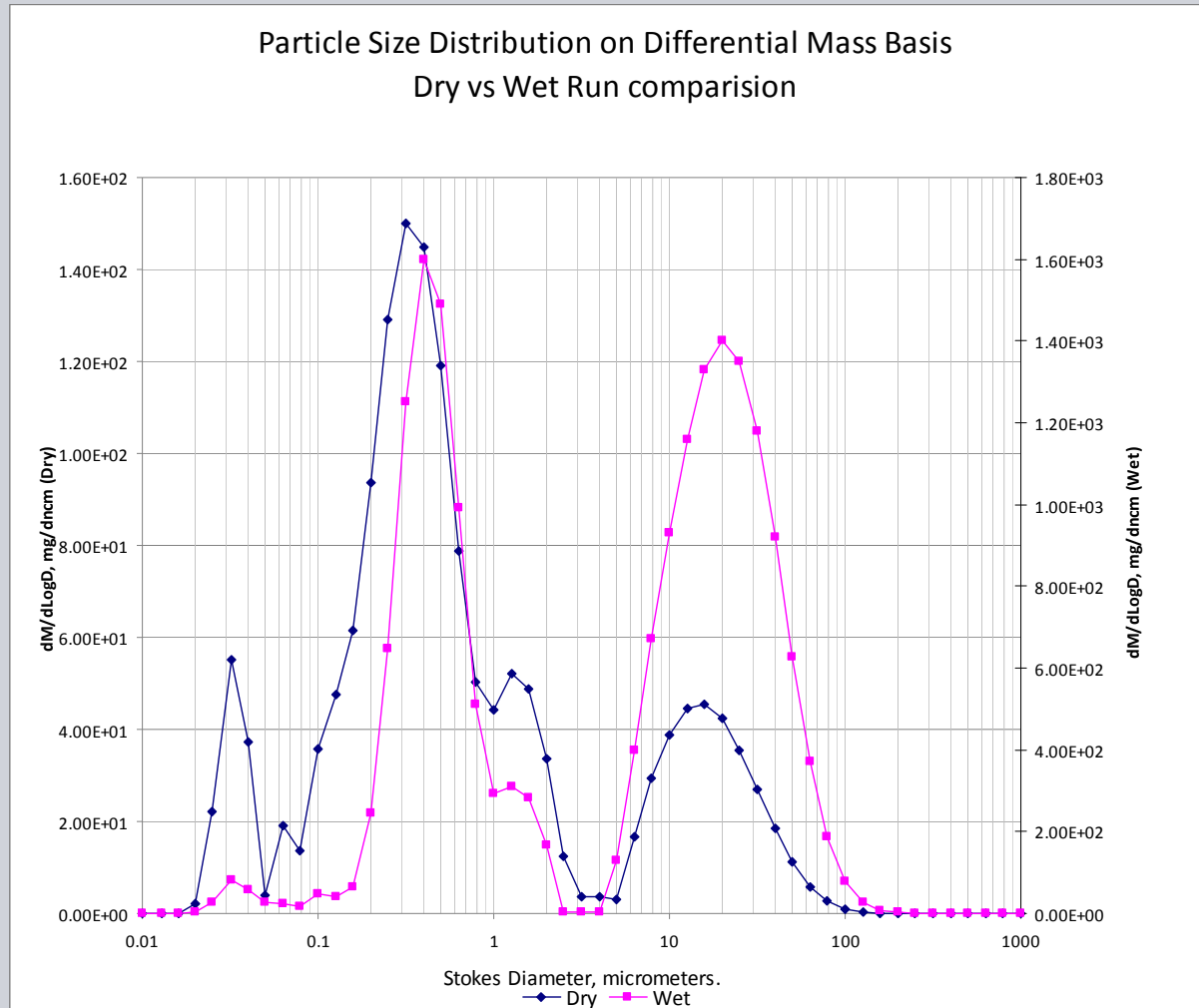

Particle Size Distribution from WFGD by Number

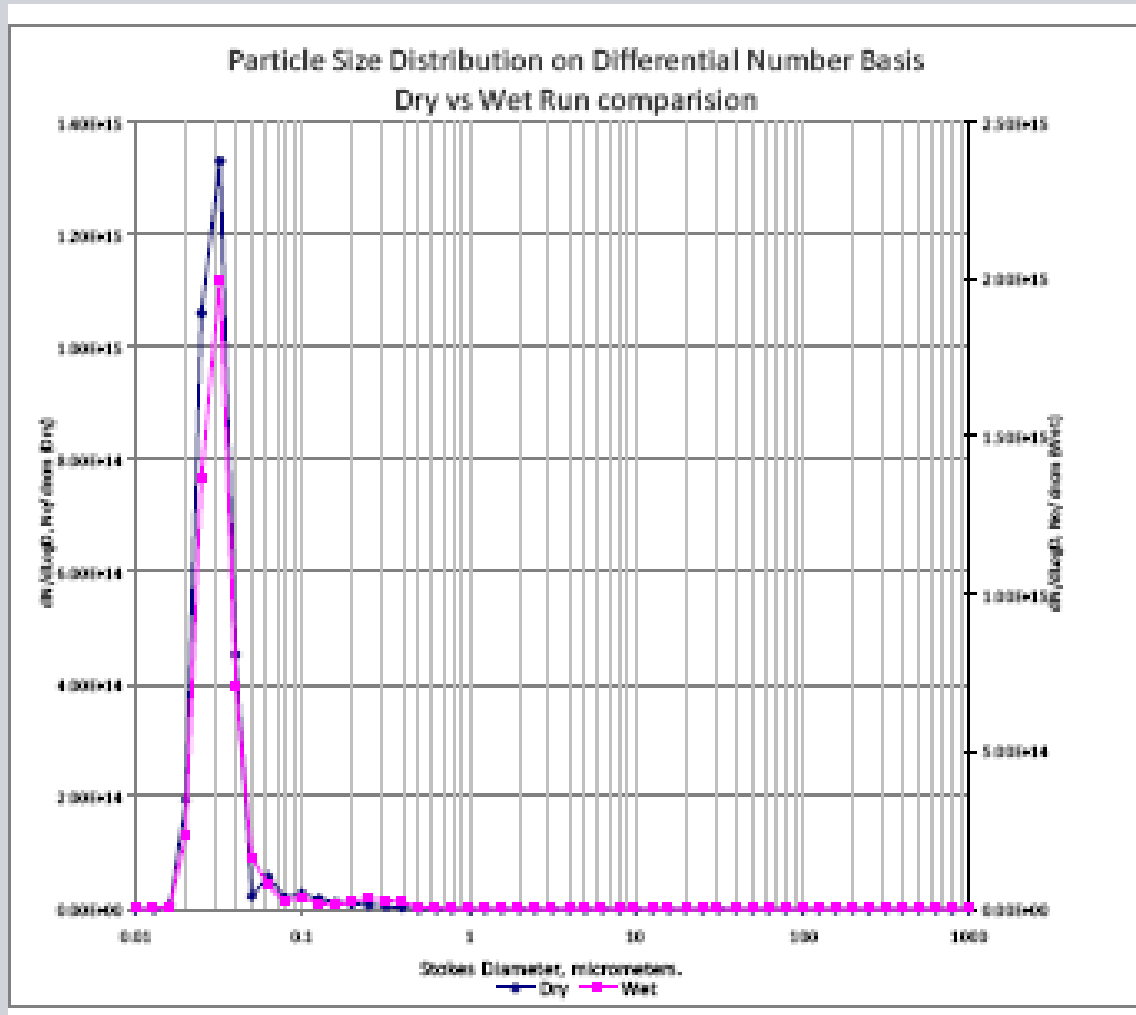

PM Removal Across Scrubber vs Pressure Drop

Figure 4-20. Venturi scrubber collection efficiencies.

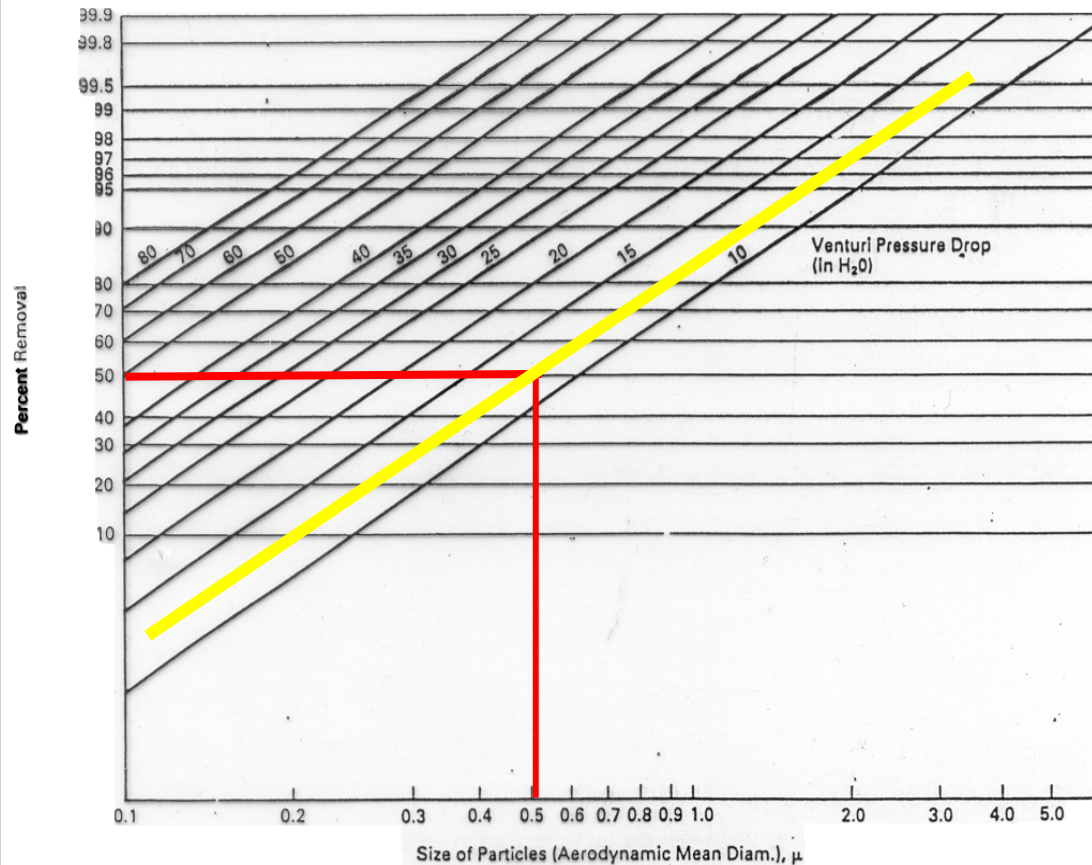

At 12" pressure drop can achieve 50% removal of 0.5 micron particles

Blue Plume” after DESP & WFGD



Sub-bituminous Coal ICR Data Control Method vs PM Standard

Slide created by Sargent Lundy

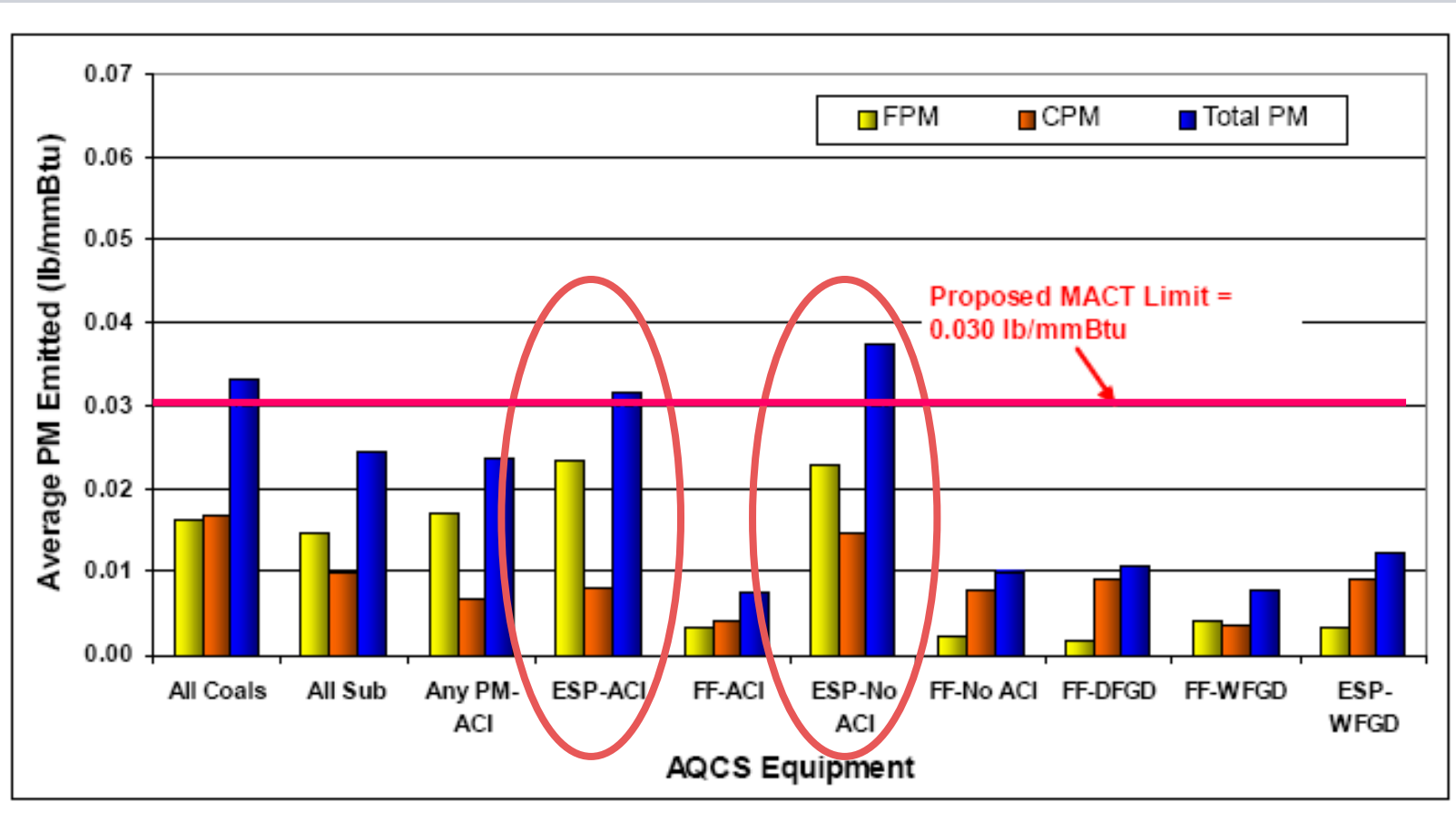

Bituminous Coal ICR Data Control Method vs PM Standard

Slide created by Sargent Lundy

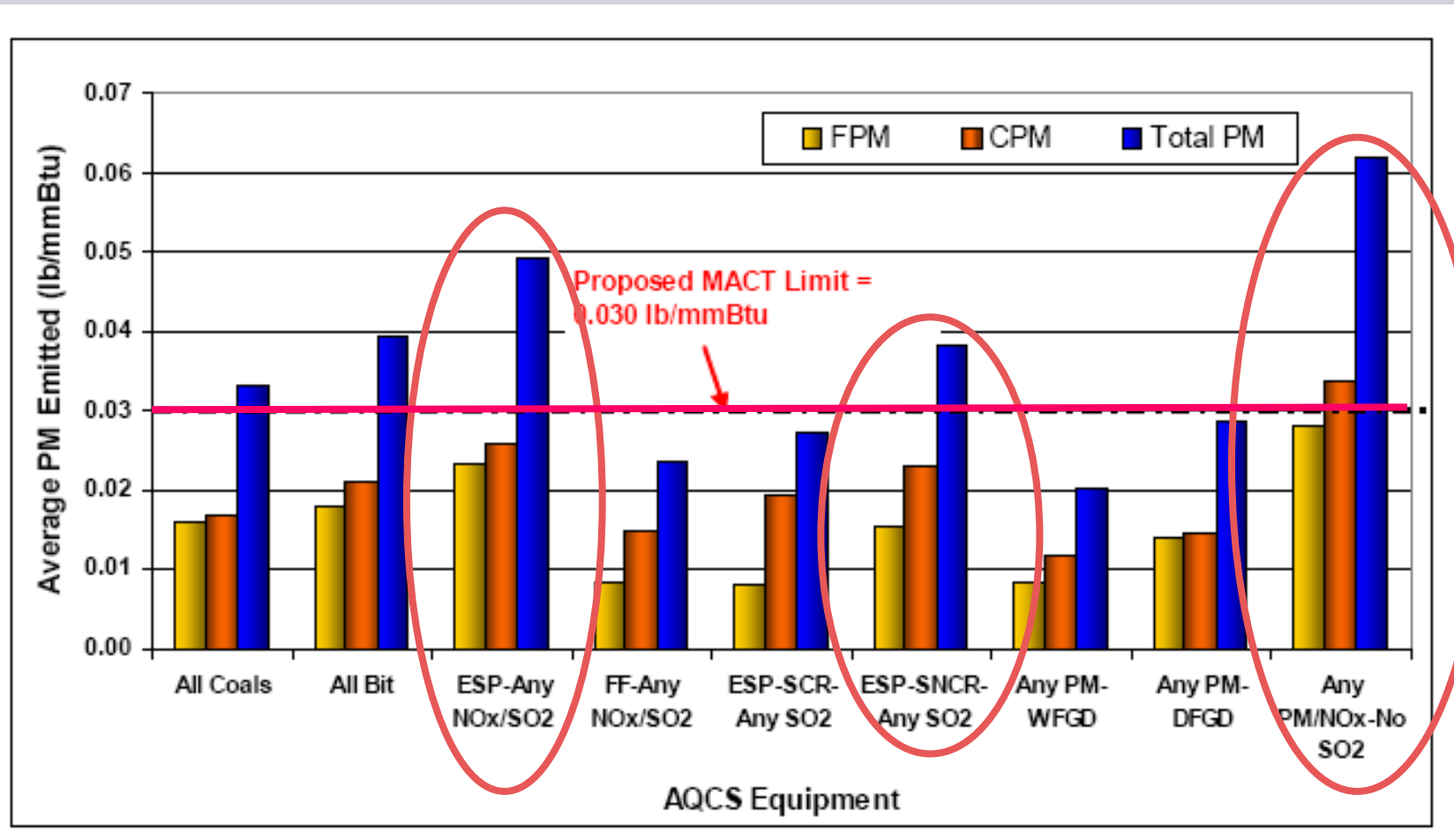

APC Configurations NOT Meeting Proposed Total PM Standards

Fuel	Existing Controls	U-MACT Suggested Equipment to Add
Bituminous Coals	Dry ESP with NO _x + SO ₂ control	DSI/FF
	Any PM/NO _x control but no SO ₂ control	DSI/FF/FGD (dry FGD or wet FGD)
Sub-Bituminous Coals	Dry ESPs with & w/o ACI	DSI/FF

Issues with DSI / FF Controls

DSI

- Increased PM loading
 - does DESP have capacity
- Increased maintenance
 - plugging issues
- Increased operating costs
 - on-going sorbent injection
- Impact on ash sales

Fabric Filter

- Increased pressure drop
 - may require new larger fans
- More real estate for FF
 - is there enough room
- On-going bag replacement
 - cost + outage time
- Increased waste by-product
 - need to landfill

Are all costs factored into overall life cycle analysis?

An Alternative Approach for PM Control – WESP Technology

Fuel	Existing Controls	U-MACT Suggested Equipment to Add	An Alternative to consider
Bituminous Coals	Dry ESP with NOx + SO2 control	DSI/FF	WESP after a WFGD
	Any PM/NOx control but no SO2 control	DSI/FF/FGD (dry FGD or wet FGD)	WESP after a WFGD
Sub-Bituminous Coals	Dry ESPs with & w/o ACI	DSI/FF	WESP after Dry ESP In lieu of FF (piloted but not demonstrated)

WESP Controls SO₃ + PM_{2.5} + Hg

NO_x → NO_x

SO_x

PM

Hg

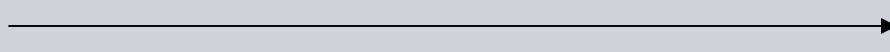

PM₁₀

Hg

SO₂

PM_{10-2.5}

Hg

SO₃
PM_{2.5}
Hg

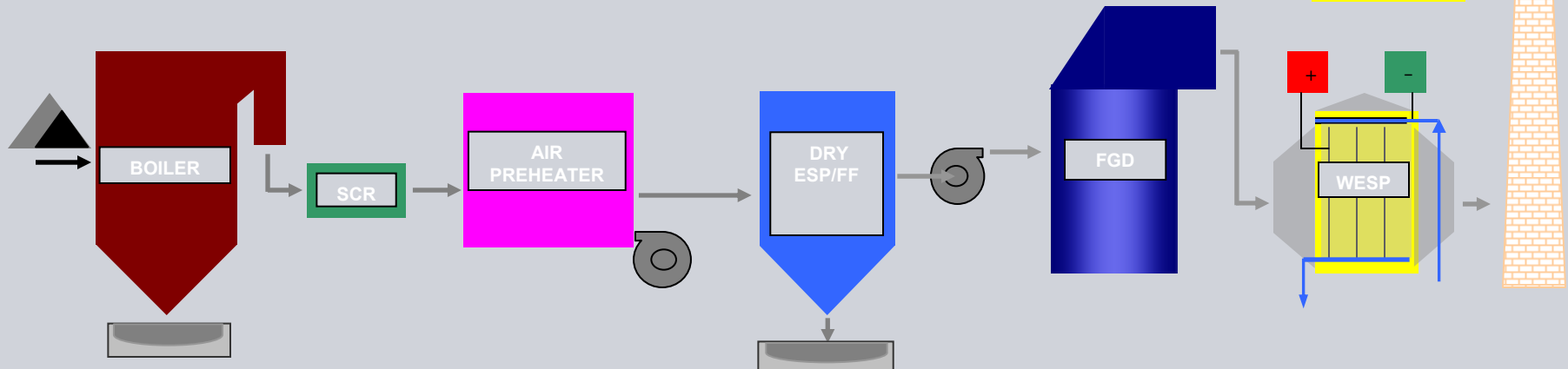

Typical Horizontal WESP after Wet FGD



Why WESP Technology

Multi-Pollutant Control

- PM_{2.5} (filterable PM)
- SO₃ (condensable PM)
- Metals
- Mercury (limited)
- > 90% control

Opacity Reduction

- <10% visible plume

Operationally

- Low Pressure Drop (@1.0")
- No Moving Parts
- Minimal Maintenance
- Self-Cleaning with water
- Water by-product goes to WFGD
- Smaller footprint than FF
- Flexible to Upset Conditions
- No impact on upstream equipment

Fuel Flexibility

Switch to lower cost, higher S coal

A Final Polishing Device

What Utility MACT says about WESP Technology

25014

Federal Register / Vol. 76, No. 85 / Tuesday, May 3, 2011 / Proposed Rules

“A facility that wants to upgrade the PM control may choose to replace the current equipment with newer, better performing equipment. The facility may consider installation of a downstream secondary PM control device—such as a secondary FF. *A Wet ESP can also be installed downstream of a wet FGD scrubber for control of condensable PM.*”

25060

Federal Register / Vol. 76, No. 85 / Tuesday, May 3, 2011 / Proposed Rules

“ Furthermore, an FGD designed for SO₂ control has the co-benefit of reducing to some extent, condensable PM emissions. Therefore, the existing NSPS baseline for control of condensable PM is a FF in combination with an FGD. *We have concluded that the additional use of a WESP system in combination with DSI is “Best Developed Technology” for condensable PM.*”

ICR DATA has 2 Plants with WESP

Microsoft Excel - Utility MACT Metals-PM database.xlsx

File Edit View Insert Format Tools Data Window Help Adobe PDF

Type a question for help

Calibri 10

EA5 FF, WFGD

	A	B	C	D	E	EA	EB	EC	
	primary_fuel	ORIS code	Plant Name	physical_state	Unit Number	Control summary	control_group_1	control_type_1	inst
2									
3	coal	7790	Bonanza Power Plant	UT	1-1	FF, WFGD	PM control	Fabric Filter, reverse air	
4	coal	2554	Dunkirk Generating Plant	NV	1	SNCR, DSI, FF	NOx control	Selective Noncatalytic Reduction	
5	coal	492	Martin Drake	CO	Unit 5 - Coal	FF, WFGD	PM control	Fabric Filter, reverse air	
6	coal	568	Bridgeport Station	CT	BHSEMU3053-#2	ESP, ACI, FF	PM control	Electrostatic precipitator, cold side, w/o flue gas	
7	coal	2712	Roxboro Steam Electric Plant	NC	Rox_Cfg_2c	SCR, ESP, WFGD	NOx control	Selective Catalytic Reduction	
8	coal	8223	Springerville	AZ	4	SCR, DFGD, FF	NOx control	Selective Catalytic Reduction	
9	coal	891	Havana	IL	Boiler 9	ESP, SCR, ACI, DFGD, FF	PM control	Electrostatic precipitator, hot side, unspecified	
10	coal	2554	Dunkirk Generating Plant	NV	4	SNCR, DSI, FF	NOx control	Selective Noncatalytic Reduction	
11	coal	7097	J K Spruce	TX	1	FF, WFGD	PM control	Fabric Filter, reverse air	
12	coal	2324	Reid Gardner	NV	1	FF, WFGD	PM control	Fabric Filter, pulse	
13	coal	2451	San Juan	NM	Unit 3	ACI, FF, WFGD	Other control	Activated carbon injection	
14	coal	2712	Roxboro Steam Electric Plant	NC	Rox_Cfg_1b	SCR, ESP, WFGD	NOx control	Selective Catalytic Reduction	
15	coal	963	Dallman	IL	34	SCR, FF, WFGD, WESP	NOx control	Selective Catalytic Reduction	
83	coal	6041	H L Spurlock Station	KY	Unit 01	ESP, SCR, WFGD, WESP	PM control	Electrostatic precipitator, cold side, w/o flue gas	
84	coal	10343	Foster Wheeler Mt Carmel Cogen	PA	SG-101	FBC, FF	PM control	Fabric Filter, reverse air	
85	coal	6021	Craig	CO	C3	DFGD, FF	SO2 control	Dry FGD - Spray Dryer	
86	coal	2324	Reid Gardner	NV	3	FF, WFGD	PM control	Fabric Filter, pulse	
87	coal	6664	Louisa	IA	101	DFGD, FF	SO2 control	Dry FGD - Circulating Dry Scrubber	
88	coal	130	Cross	SC	C1	SCR, ESP, WFGD	NOx control	Selective Catalytic Reduction	
89	coal	6113	Gibson	IN	2-2007-FGDIN	SCR, ESP, WFGD	NOx control	Selective Catalytic Reduction	
90	coal	52071	Sandow Station	TX	5B	FBC, SNCR, ACI, DFGD, FF	NOx control	Selective Noncatalytic Reduction	
91	coal	4041	South Oak Creek	WI	OCPP-B8	ESP	PM control	Electrostatic precipitator, cold side, w/o flue gas	
92	coal	2324	Reid Gardner	NV	2	FF, WFGD	PM control	Fabric Filter, pulse	
93	coal	1710	Consumers Energy - J.H. Campbell	MI	JHC2-Conf	ESP	PM control	Electrostatic precipitator, cold side, w/ flue gas conditioning	
94	coal	1710	Consumers Energy - J.H. Campbell	MI	JHC1-Conf	ESP	PM control	Electrostatic precipitator, cold side, w/o flue gas	
95	coal	56224	TS Power Plant	NV	TSPower	SCR, ACI, DFGD, FF	NOx control	Selective Catalytic Reduction	
96	coal	4042	Valley	WI	VAPP-B3	FF	PM control	Fabric Filter, pulse	
97	coal	4042	Valley	WI	VAPP-B2	FF	PM control	Fabric Filter, pulse	
98	coal	6170	Pleasant Prairie	WI	PPPPB2	SCR, ESP, WFGD	NOx control	Selective Catalytic Reduction	
99	coal	8224	North Valmy	NV	2	DFGD, FF	SO2 control	Dry FGD - Spray Dryer	
100	coal	3138	New Castle Plant	PA	NC3-2	SNCR, ESP	NOx control	Selective Noncatalytic Reduction	

Summary / PM_avg_MMBtu / PM_New_MMBtu / PM_coal_MMBtu / PM_avg_MW / PM_New_MW / Total_Metal_avg_MMBtu / Total_Metal_New_MMBtu

Ready

start 2011 Reinhold - U... Utility MACT stuff Adobe Acrobat St... Microsoft Excel - ... EN 10:43 PM

Total PM Emissions ICR Data vs WESP Data



	# of Units	Range of PM	Ave PM Lb/MMBtu
PM Limit			0.03
All ICR Units	1091	8.60E-06 to 2.96E-01	0.0388
Top 12% average	131	8.60E-06 2.56E-02	0.0116
Dallman Unit 3	1		0.0050
HL Spurlock Unit 1	1		0.0060

New Coal Plant WESPs not in ICR Data

Facility	Unit Size (MW)	Fuel	APC Control Technology	Status
Elm Road	2 x 615	Pittsburgh #8	FF / WFGD / WESP	Online
Trimble County	750	Blend of Bituminous & Sub-bituminous	ESP / FF / WFGD / WESP	Online 2011
Prairie States	2 x 750	Southern IL Bituminous	ESP / WFGD / WESP	Fall 2011 & Spring 2012

Trimble County APC Equipment

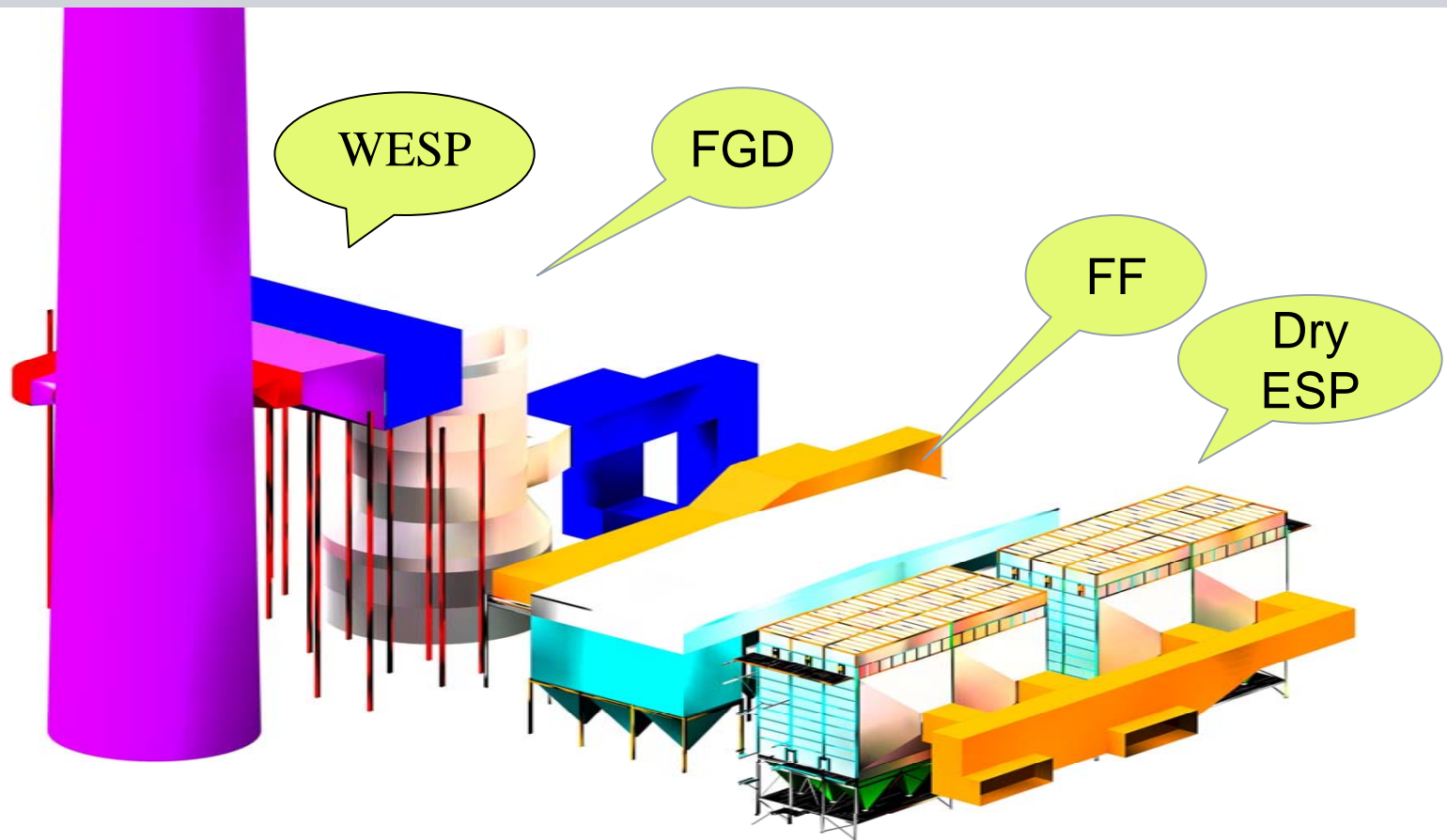

Older WESP Utility Installations

Facility	Unit Size (MW)	Fuel-Fired	Number of WESP Modules	WESP Flow Configuration
AES Deepwater USA	155	Pet Coke	12 (external to FGD)	Vertical plate 3-field
Sherco 1 & 2 USA	750 ea.	PRB Coal	12 per unit (retrofit into each existing wet scrubber absorber)	Vertical tube 2-field
Dalhousie 1 & 2 Canada	315 total	Orimulsion	1 (retrofit into existing FGD absorber tower)	Vertical tube single field
Dakota Gasification USA	420 equiv.	Waste liquids from coal gasification process	1 (external to existing FGD absorber tower)	Horizontal plate 3-field
Coleson Cove Canada	3x350	No. 6 Oil	2 (integral to each of 2 retrofit FGD absorber towers)	Vertical plate 3-field

Typical WESP Performance - Opacity

Courtesy of EPRI

NSP Sherco Unit 1 & 2 Stack Opacity History (SEI, FLS, B&W)

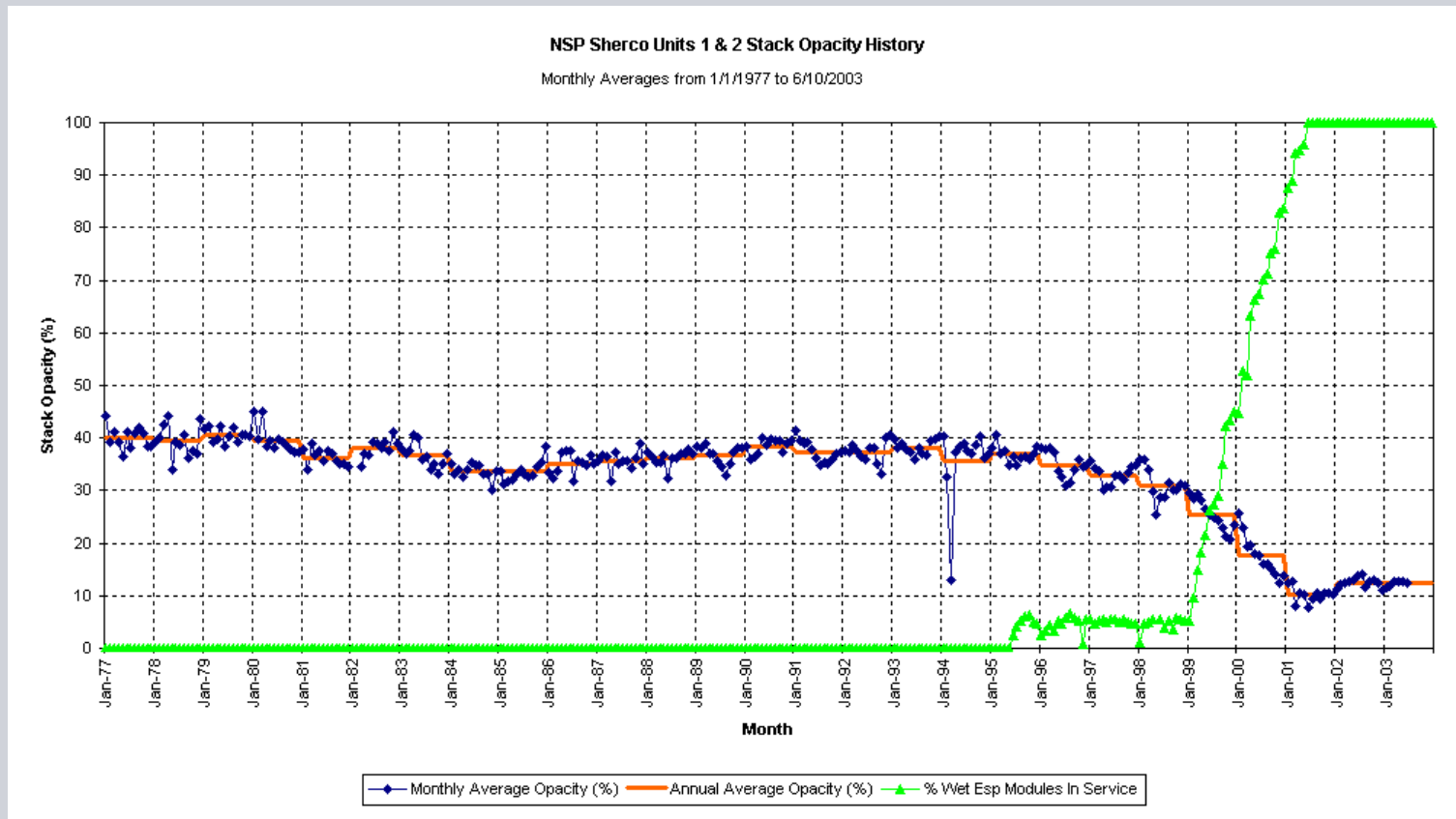

Typical WESP Performance PM2.5 & SO3 Test Results



Summary of Pilot Wet ESP –PM2.5 & SO3 Test Results- Bruce Mansfield Plant –2001-2003								
Average	PM2.5 (EPA Test Method 5)				SO ₃ Mist (EPA Test Method 17 modified to Controlled Condensation)			
	URS Testing		OU Testing		URS Testing		Ohio U.	
Test Series	Sep-01	Nov-01	Nov-02	July-03	Sep-01	Nov-01	Nov-02	Oct -03
Airflow-acfm	8394	8235	N/A	8000	8394	8235	8000	8000
Velocity –ft./sec.	10	10		10	10	10	10	10
# of fields	1	2		2	1	2	2	2
Power Levels	100%	100%		100%	100%	100%	100%	100%
units	gr/dscf	gr/dscf		mg/m ³	ppm	ppm	ppm	ppm
Inlet	0.0292	0.0506		125	11.5	10.01	8.9	2.9
Outlet	0.0063	0.002		9	2.7	0.85	1.0	0.35
Removal %	79%	96%		93%	76%	92%	89%	88%

Note: WESP designed for 90% removal at 5,000 acfm.

Testing performed at 8,000 acfm, 60% beyond design point.

WESP Performance - Mercury

Incremental Hg Removal Efficiency (Ontario Hydro Test Method)							
	FGD Inlet		FGD outlet		Wet ESP outlet		Total
	$\mu\text{g}/\text{m}^3$	Removal%	$\mu\text{g}/\text{m}^3$	FGD %	$\mu\text{g}/\text{m}^3$	WESP %	FGD/WESP Removal %
Ash Hg	4.37	0%	0.85	80%	0.20	76%	95%
Hg²⁺	6.02	0%	1.88	69%	0.26	86%	96%
Hg⁰	2.55	0%	2.92	-15%	2.39	18%	6%
Total Hg	12.94	0%	4.88	62%	2.85	41%	78%

Limited pilot testing shows some Hg co-benefit

Internal Safety Margins

PM Assumptions 1ppm = 0.003 lb/MMBtu	Proposed Limit	Utility Operating Margin = 20%	Vendor Guarantee Margin = 20%	PPM
Filterable PM (50%)	0.015 lb/MM Btu	0.012 lb/MMBtu	0.0096 lb/MMBtu	3.2 ppm
Condensable PM (50%)				
H ₂ SO ₄ (33%)	0.010 lb/MMBtu	0.008 lb/MMBtu	0.0064 lb/MMBtu	2.1 ppm
Metals (17%)	0.005 lb/MMBtu	0.004 lb/MMBtu	0.0032 lb/MMBtu	1.0 ppm
Total Condensable PM	0.015 lb/MMBtu	0.012 lb/MMBtu	0.0096 lb/MMBtu	3.2 ppm
Total PM	0.03 lb/MMBtu	0.024 lb/MMBtu	0.0192 lb/MMBtu	6.4 ppm

- Will DSI/FF get you to @ 2 ppm H₂SO₄?
- Even if over-control FPM to 0.0 lb/MMBtu H₂SO₄ can be no more than 5-6 ppm
- What happens if you have WFGD carryover?

Other Thoughts

- To minimize risk of not meeting U-MACT standards consider using existing DESP / WFGD with WESP or DSI+WESP
- U-MACT Rule waives monthly testing if no CEMS for 3 years if emissions are 50% of standards for 3 years
- U-MACT Rule standards may become more stringent in 5 years. Will what you do today make it in the future?
- If plant is baseload unit that you plan to operate for the long term a WESP option may be more economical choice than DSI/FF
- If WFGD is creating particulate carryover no DSI/FF will help. Need a polishing WESP to remove post WFGD PM
- WESP can be ON during start-up/shutdown

WESP Requirements

- Water
 - First use of WFGD water & give back to WFGD
 - No additional burden on plant
- Materials of Construction
 - High End Alloys – 316L, 317LMN, 2205, AL6XN, Hastelloy
 - MOC minimized by reducing size through electrical sectionalization

New Application: Hybrid Dry-Wet ESP

- WESP after Dry ESP
- Operates 50°F above saturation to prevent downstream corrosion
- < 1" pressure drop
- Possible solution for smaller plants with limited real estate & fan

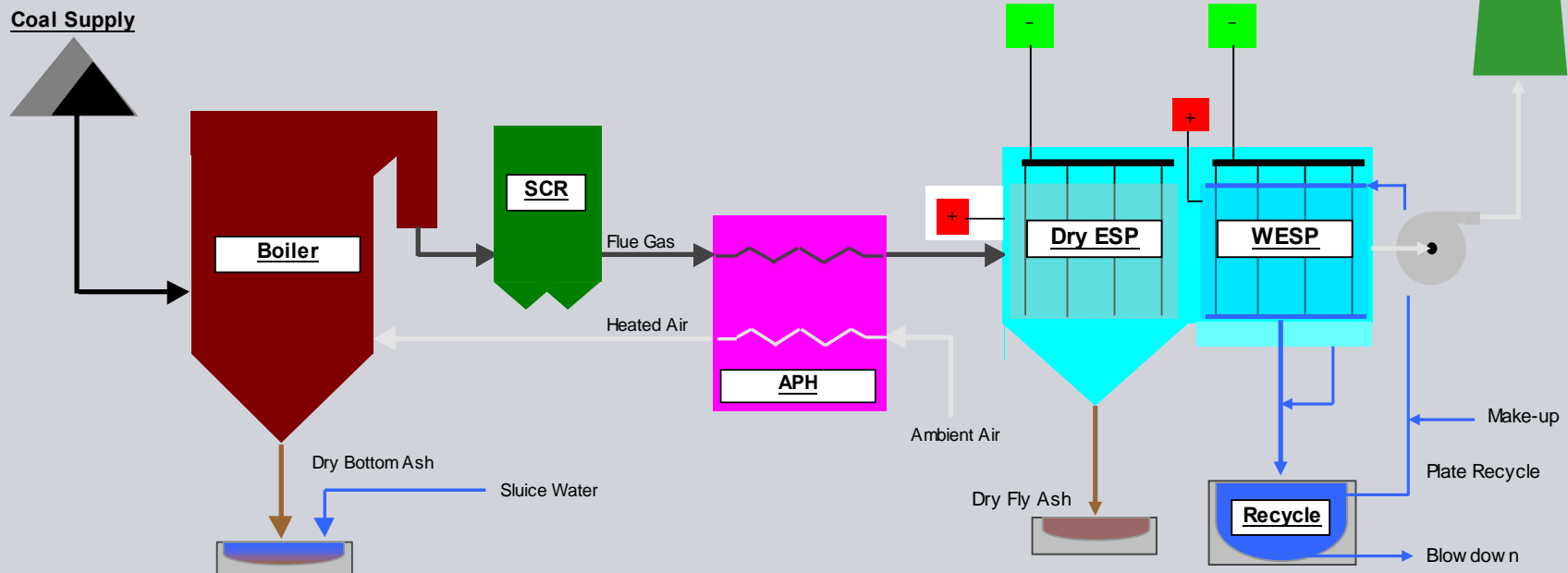

New Technology: Plasma Enhanced ESP for Hg Control

SIEMENS

- PEESP oxidizes Hg^0
- > 90% oxidation pilot unit tested
- Operates at duct velocity
- Allows WFGD to remove more total Hg
- Replaces PAC injection with reagent injection through corona field

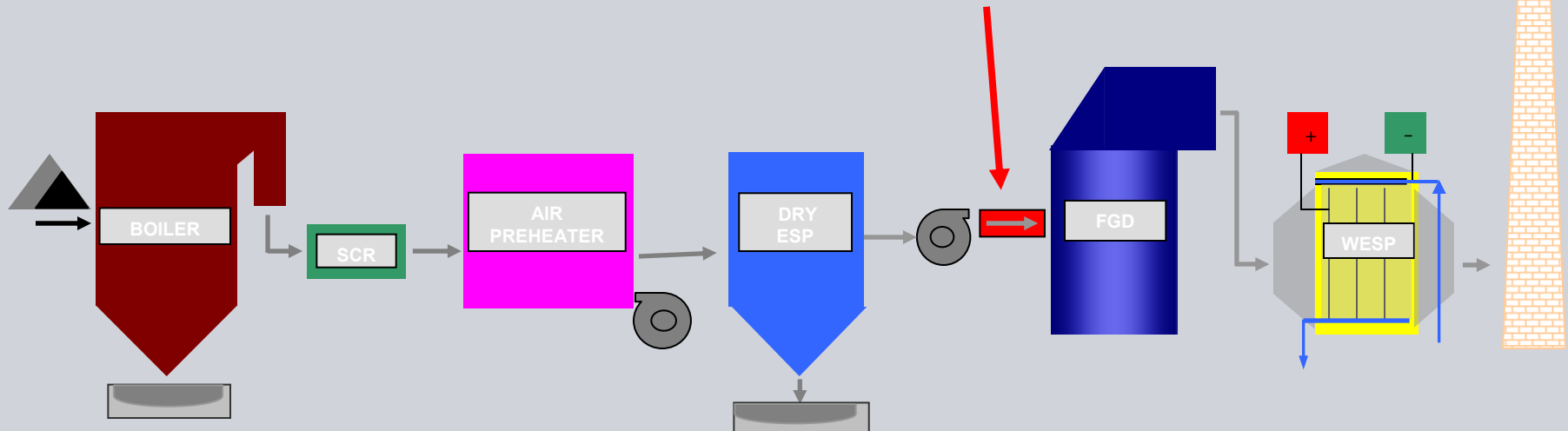

Slip-Stream Pilot Hybrid Wet ESP with PEESP



- Alabama Power
- Plant Miller
- PRB Coal
- 2 MW Slip-stream

Acknowledgements

Clean Air Engineering – slides #9 & #10

Sargent Lundy – slides # 13 & 14

EPRI for slide # 26

THANK YOU

SIEMENS

Buzz Reynolds

VP – Wet ESP

Siemens Environmental Systems & Services

Siemens Energy

501 Grant Street

4th Floor

Pittsburgh, PA 15219

jamesreynolds@siemens.com

908 -522-6616